

LOC	DIST	REVISIONS					
BD	35	P	LTR	DESCRIPTION	DATE	DWN	APVD
		A1		REVISED PER ECO-08-022750	17SEP08	HMR	BC

- △1 FINISH: ZINC PLATE WITH CLEAR CHROMATE
- △2 FINISH: ZINC PLATE WITH NON-HEXAVALENT CHROMATE

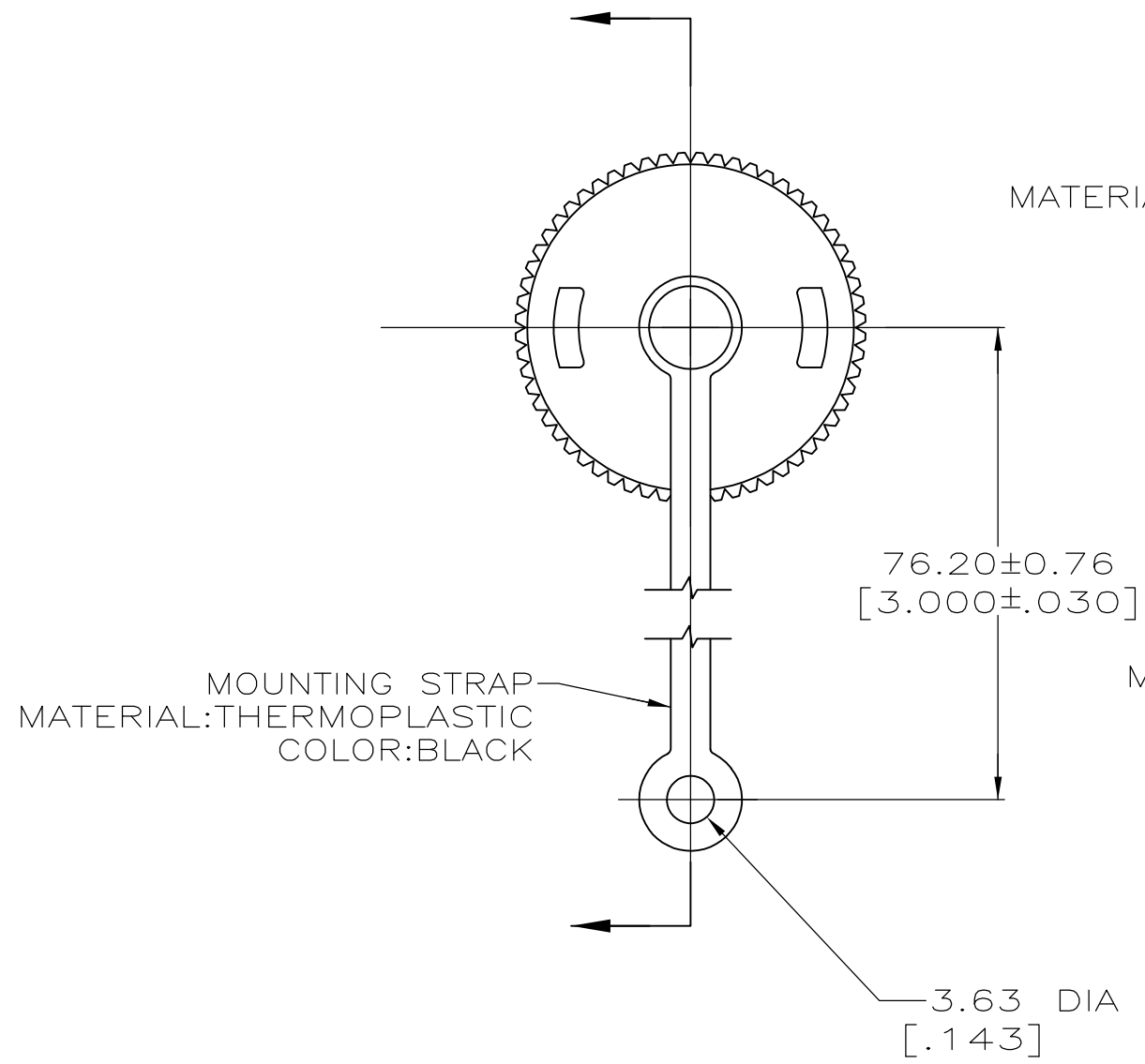

MATERIAL:CARBON  
 △1△2

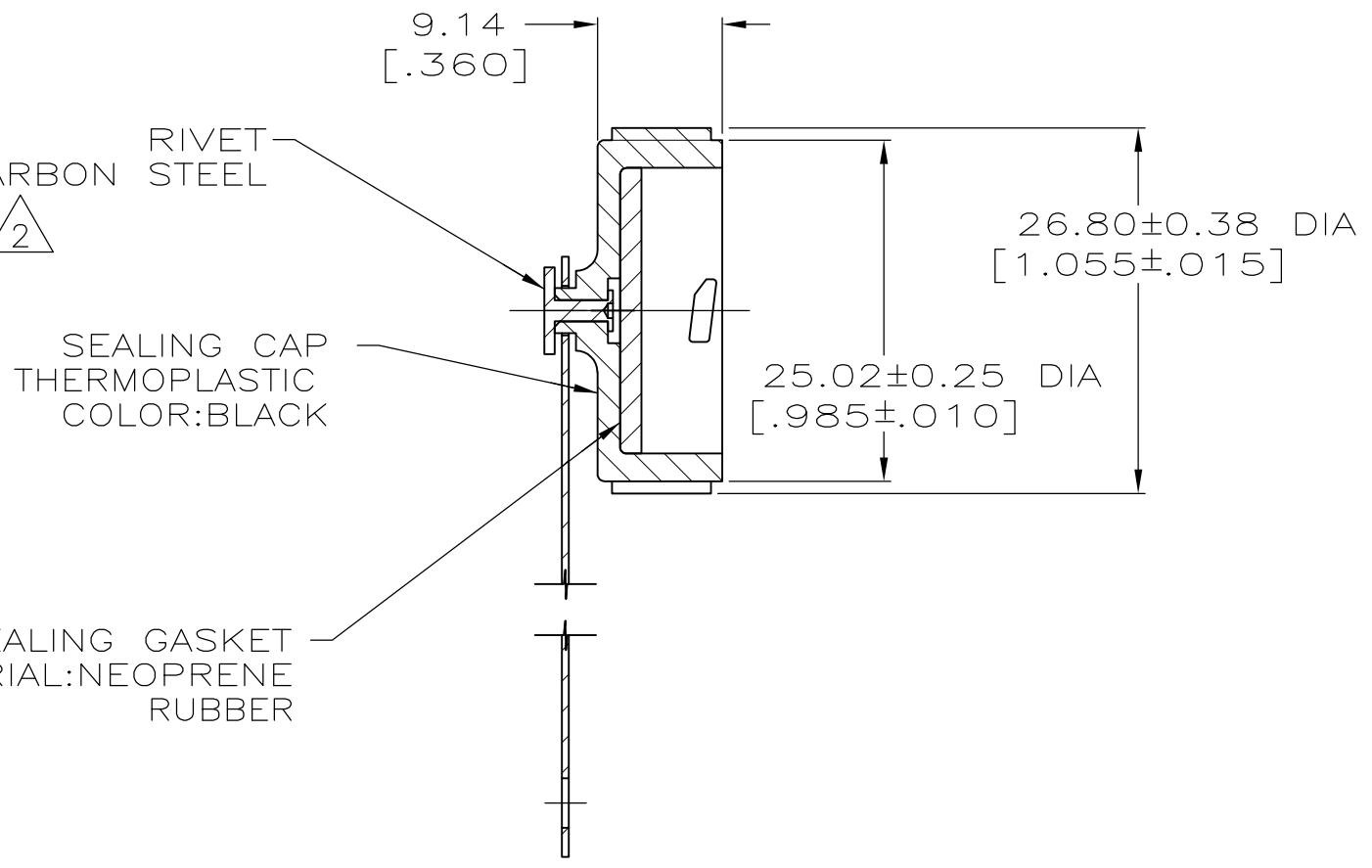

△2	211870-2
△1	211870-1
FINISH	PART NUMBER

THIS DRAWING IS A CONTROLLED DOCUMENT.		DWN D.BROCKWAY 6-9-93	Tyco Electronics Corporation Harrisburg, PA 17105-3608	
DIMENSIONS: mm [INCHES]		CHK R.STONE 7-1-93		
TOLERANCES UNLESS OTHERWISE SPECIFIED:		APVD AL FRANTUM 7-1-93	NAME SEALING CAP ASSY, SIZE 13, CPC	
0 PLC ± - 1 PLC ± - 2 PLC ± 0.13[.005] 3 PLC ± - 4 PLC ± - ANGLES ± -		PRODUCT SPEC -	RESTRICTED TO -	
MATERIAL SEE CALLOUTS		FINISH SEE CALLOUTS	APPLICATION SPEC -	SIZE A3
		WEIGHT -	CAGE CODE 00779	DRAWING NO C-211870
CUSTOMER DRAWING			SCALE 2:1	SHEET 1 OF 1
			REV A1	